

DO NOT SCALE

DIMENSIONS MAY VARY BY PLUS OR MINUS 2.5% DUE TO THE ROTATIONAL MOULDING PROCESS

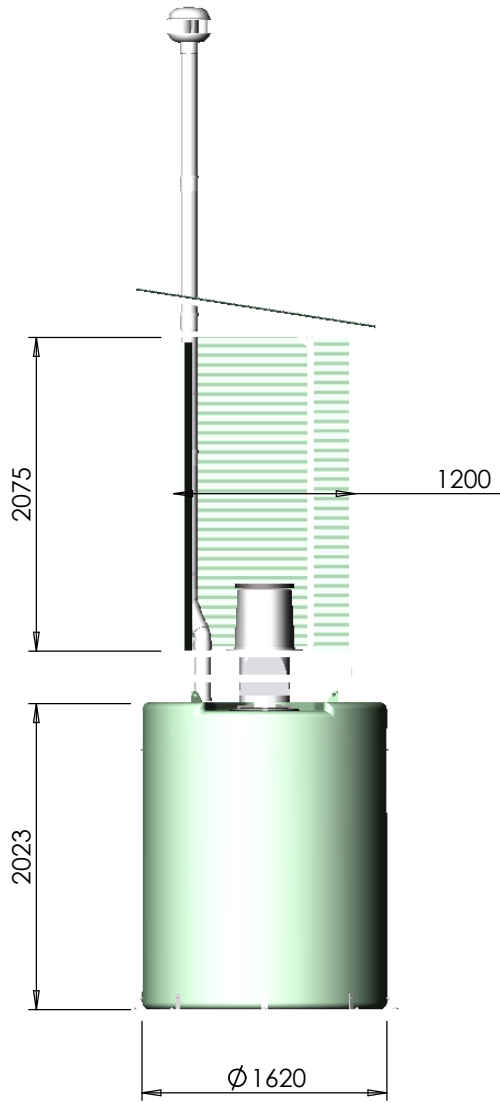

FRONT VIEW

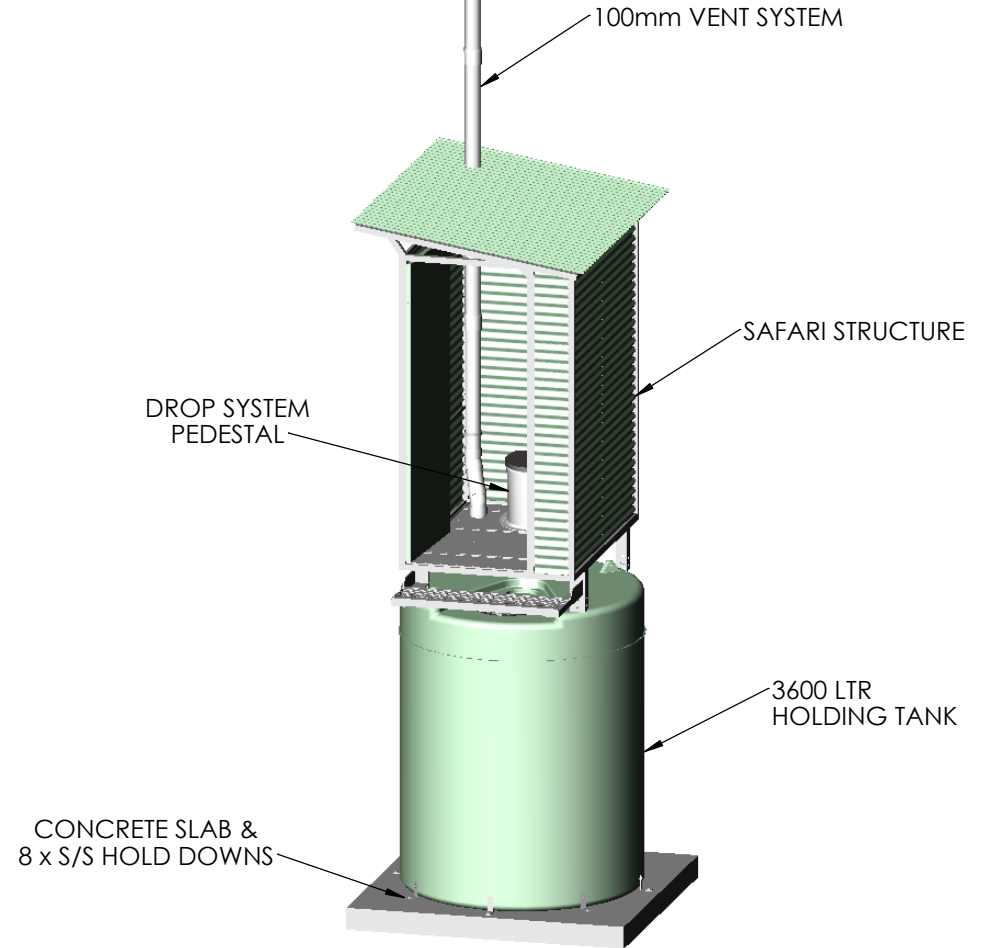

DIMETRIC VIEW

| No. | DATE | BY | DESCRIPTION | GOUGH APPROV. |
|-----|------|----|-------------|---------------|
| | | | | |
| | | | | |
| | | | | |
| | | | | |
| | | | | |
| | | | | |
| | | | | |
| | | | | |
| | | | | |



Gough Industries Pty. Ltd.
 833 Ingham Road
 Bohle, Townsville
 P.O. Box 7570, Garbutt BC, Qld. 4814.
 Telephone 07 47747606
 Facsimile 07 47747608
 A.C.N. 010 028 547

| | | |
|---------------------|-----------|----------|
| DRAWN | Signature | Date |
| DRN_CHK | S.NAGY | 15.03.05 |
| ENGINEER | | |
| ENG_CHK | | |
| Eng. APPROVAL | | |
| CONTROLLED DOCUMENT | | NO |

| | | |
|---------------------------------------|--|--|
| KARIJINI NATIONAL PARK - VAULT SYSTEM | | |
| GENERAL ARRANGEMENT DETAILS | | |
| SCALE 1:50 | A4 | Gough Plastics Drg. No. HTS980.0005-01 |
| CAD FILE: | S:\Products\Hybrid Toilet System\Drawings\Custom Systems\WA\Karijini NP\ | |